



CASE STUDY

Bridge T8 Egnatia MotorWay





DESCRIPTION

Modern Egnatia Motorway borrows its name from the homonymous Roman work which was built between 146-120 BC, on the traces of an ancient Roman road stretching from Adriatic to Aegean.

Nowadays, there is a 680 km closed motorway, starting from Igoumenitisa, crossing Epirus, northern Greece ending at Evros, the Greek-Turkish border. It contains a number of tunnels, bridges and interchanges being in the completion phase.

TECHNICAL SPECIFICATIONS

- Two-lane motorway per branch, with a separating traffic island and a right-hand Emergency Lane.
- 62 connection knots through road
- 350 upper and lower entry / exit crossings
- 529 large bridges, total length 40 km.
- 73 tunnels with a maximum length of 4.8 km. and a total length of 49.5 km or 99 km
- 43 river passes
- 11 crossroads with railway lines

The section from Arachthos A / C to Chrysovitassas - Peristerios is 9km long. This is one of the most difficult parts especially from the exit of the T8 tunnel to the Chrysovitssa A / C because of the intense geotechnical problems that needed special measures to stabilize the lands. The final study was completed in spring 2006 where the project was auctioned. With the completion of the project, travel time is reduced by approximately 40 minutes from the center of Ioannina to Metsovo while the traffic safety is significantly increased.

In the section of Egnatia Motorway, Drosochori - Arachthos, on behalf of the contractor AEGEK, metal deck was constructed, consisting of two traffic sectors with a total length of 650m. The total width is 13.70m including two traffic lanes of 3.75 m, emergency lane of 2.50m, two pavements 1.00m each to express lane and 1.25m emergency lane as well as two lateral lanes of 0.50m and 0.95m.

STUDY & DESIGN

The bridge was designed on the basis of the German regulations in valid until 2003 and some issues were covered in accordance with the methodology developed in the EC3 and EC4 Eurocodes. The seismic design of the project was carried out in accordance with ESA 2000 and the Greek Guidelines for the Design of Bridges in Seismic Areas. The extremely short construction time, the inaccessibility of the area and the winter season were taken into account.

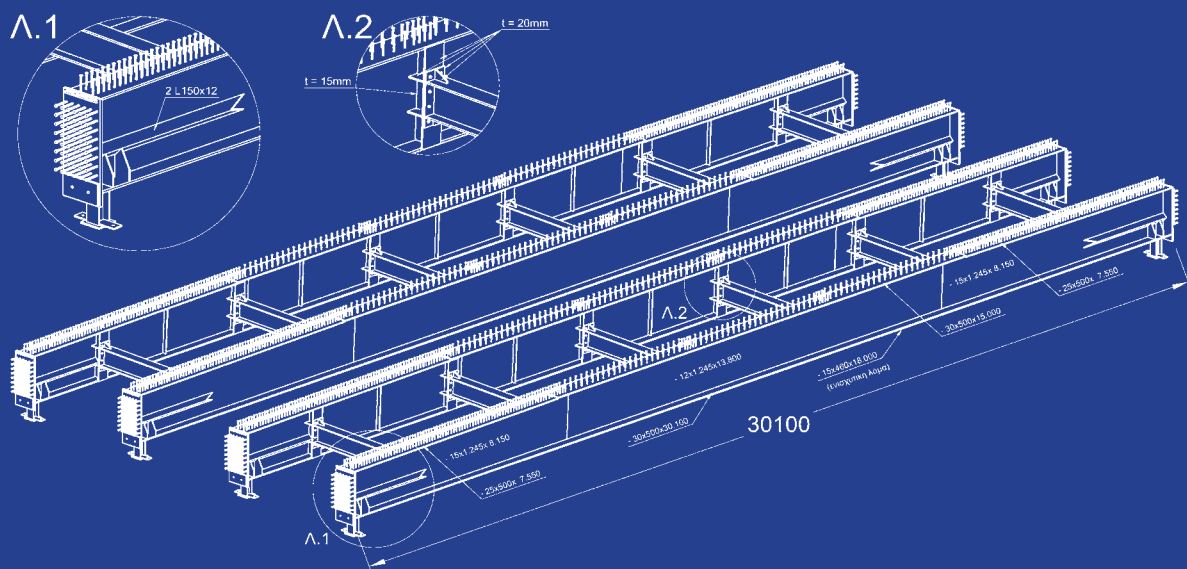

The bridge consists of two practically parallel branches with a composite continuous deck, supported by elastomeric bearings on reinforced concrete frames, consisting of circular columns and rectangular cross section. Due to the length of the bridge and the soil morphology, each branch bridge is subdivided by a joint into two sub-bridges of approximately ~ 175.0m. Each subway has 6 openings with a variety length as it follows: 25.20 - 31.00 - 31.00 - 31.00 - 31.00 - 25.20. The cross section is formed with 4 composite steel rods, 1.30m high, connected together by a horizontal joint and a circular plate of 0.32m thick, with a total depth of deck of 1.6m. Shear connections on this composite steel/concrete structures was made by "Nelson" type headed studs.





Basic element without a union concerned the length of the beams ~ 30m, benefiting from increased strength, road transport, reduction of erection time and reduced maintenance requirements.



STEEL BRIDGES

Materials Specifications

The S355 J2 G3 (St 52.3N) was classified as S355 J3 (St 52.3N) according to EN 10113. For the S355 J0 diaphragm, (St 53.3U) and the leakage and failure limits were proportional to the thickness of the steel sheet. Nelson studs of 22/200 and 19/225 bolts of S235 J2 G3 + C450 steel (ST 37-3K) were used in shear joints, while screws were generally of Class 8.8.

Paint System

For environment C2, a nominal life of more than 15 years and a degree of wear of Ri3, the following dyeing system was completely factory-fitted, exceeding the requirements of standard EN ISO 12944. In all cases the primer application was performed immediately after sandblasting the same day. a) The visible surfaces were Sa 2½ sandblasting, Basic primer primer 80 µm, 100 µm Intermediate 100 µm epoxy base layer and 60 µm final polyurethane base with a total thickness of 240 µm. b) At the concrete / steel interfaces, Sa 2½ sandblasting, 80 µm Base Epoxy Primer was applied while another layer of 60 µm thick epoxy was applied to all corners at a depth of 25 mm from the edge. c) Saw bundles Sa 3, and a 40 µm zinc alumina base primer.



Controls & Certificates

Material Certifications according to EN 10204 3.1B. Welding processes according to EN 288-2. Certificate of welding processes according to EN 288-3, EN 14555. Certificate of welders according to EN 287-1. Size checks according to EN 1090-1. Visual inspection of welds according to EN 970, EN 25817 / C. Extrusion control with penetrating fluids according to EN 571, EN 25817 / C. Recordings instead of the previous point in accordance with EN 1290, EN 25817. Ultrasonic beam welding of weld beams according to EN 1712, -13, -14 / CLAS83. Radiographic control instead of the previous EN 1435, EN 25817 / C. Inspection of log seams with penetrating fluids according to EN 571, EN 25817 / C. Recordings instead of the previous point according to EN 571, EN 25817 / C. Preparation of surfaces for painting. Sandblast Sa 2.5 according to ISO 12944-5. Dyeing thickness measurements according to ISO 12944-5. Dye Protocols according to Technical Specification. Inspections of shearing poles according to ELOT EN ISO 14555.



Construction Details

In order to cope with the bending arrow of the steel rods, a pre-conditioning was provided during their manufacture. The steel rods are connected in place at two intervals with the cross members and the horizontal coupling and are placed as crane joints on the pedestals, on temporary bearings. On the already installed steel rods are placed with the crane the prefabricated panels, on which the reinforcement of the circular plate is laid, while the two outer cantilevers of the plate are concreted in two phases.





 **K. LIAROMATIS**
STRUCTURAL STEELWORK

Patras
Industrial Area
GR 250 18 - Greece

PLANT
TEL: +30 2610 647491
FAX: +30 2610 647494

ATHENS OFFICE
TEL: +30 210 2723252
FAX: +30 210 2719820

info@liaromatis.gr
www.liaromatis.gr